



Formal Methods For Web Service Process Modeling

**Dr. Yuhong Yan
NRC-IIT**



Modeling Web Service Processes with Petri Nets

Petri nets

- A marked place/transition net (P/T Net) is a tuple (P, T, F, k, w, m_0) , where

(P, T, F) is a net with

- P is a finite set of places,
- T is a finite set of transitions, $(P \cap T = \emptyset)$
- $F \subseteq (P \times T) \cup (T \times P)$ is a finite set of arcs, the flow relation.

$k : P \rightarrow \{1, 2, 3, \dots\} \cup \{\infty\}$ partial capacity of the places (default: ∞)

$w : F \rightarrow \{1, 2, 3, \dots\}$ weight function (default:1)

$m_0 : P \rightarrow \{0, 1, 2, \dots\}$ a marking satisfying $p \in P : k(p) = \infty \vee m_0(p) \leq k(p)$
(initial marking)

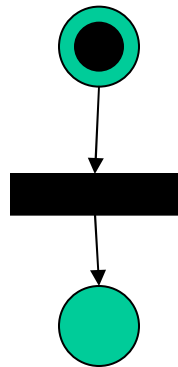



The occurrence rule

- A transition t is enabled a marking m if
 - Every place $p \in {}^\bullet t$ satisfies $m(p) \geq w(p, t)$
 - Every place $p \in t^\bullet$ satisfies $m(p) + w(t, p) \leq k(p)$
- The occurrence of t leads to the successor marking m' , defined by

$$m'(p) = \begin{cases} m(p) & \text{if } p \notin {}^\bullet t \text{ and } p \notin t^\bullet \\ m(p) - w(p, t) & \text{if } p \in {}^\bullet t \text{ and } p \notin t^\bullet \\ m(p) + w(p, t) & \text{if } p \notin {}^\bullet t \text{ and } p \in t^\bullet \\ m(p) - w(p, t) + w(t, p) & \text{if } p \in {}^\bullet t \text{ and } p \in t^\bullet \end{cases}$$

- Notation

$$m \xrightarrow{t} m'$$

$$m[t]m'$$



Occurrence sequences and reachability

- A finite sequence $\sigma = t_1 t_2 \dots t_n$ of transitions is a **finite occurrence sequence** leading from m_0 to m_n if

$$m_0 \xrightarrow{t_1} m_1 \xrightarrow{t_2} \dots \xrightarrow{t_n} m_n$$

- A marking m is **reachable** (from m_0) if there is an occurrence sequence leading from m_0 to m
- **Notation:** $[m_0\rangle$ is the set of all reachable markings
- An infinite sequence $\sigma = t_1 t_2 t_3 \dots$ is an **infinite occurrence sequence** enable at m_0 if

$$m_0 \xrightarrow{t_1} m_1 \xrightarrow{t_2} m_2 \xrightarrow{t_3} \dots$$



Behavioral Properties of Market p/t-nets

A market p/t-net is

- **Terminating** – if there is no infinite occurrence sequence
- **Deadlock-free** – if each reachable marking enables a transition
- **Live** – if each reachable marking enables an occurrence sequence containing all transitions
- **Bounded** – if, for each place p , there is a bound $b(s)$ such that $m(s) \leq b(s)$ for every reachable marking m
- **1-safe** – if $b(s) = 1$ is a bound for each place p
- **Reversible** – if m_0 is reachable from each other reachable marking

Petri Nets Blocks

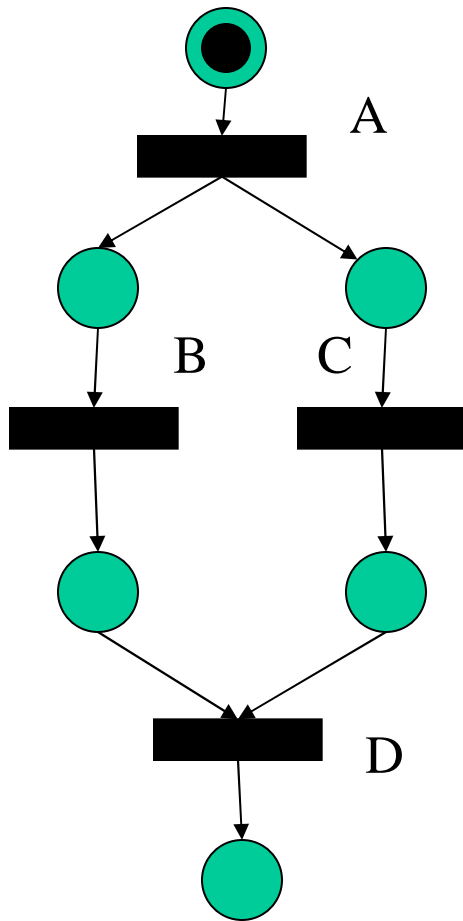

B parallels with C

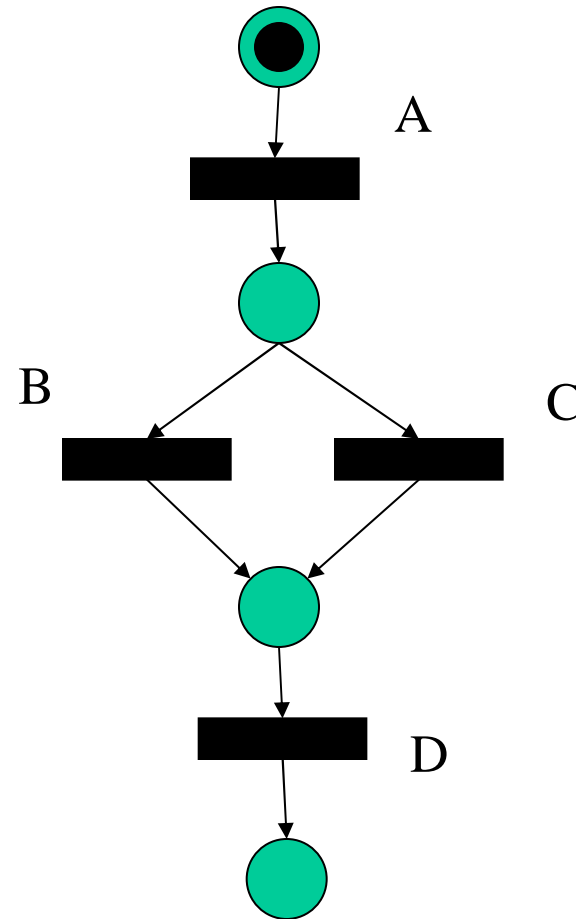

B or C

The Petri Net for the Example Process

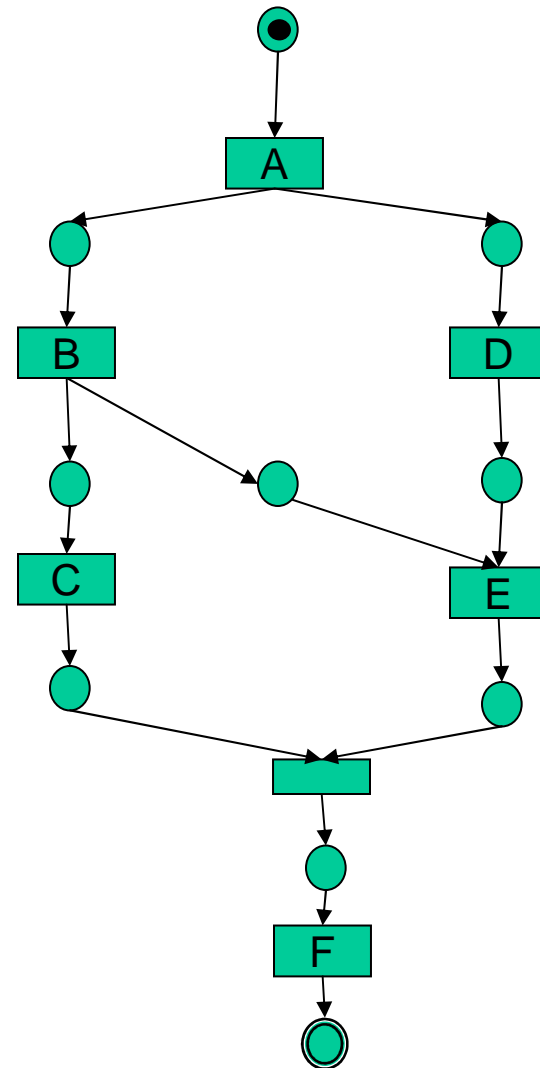
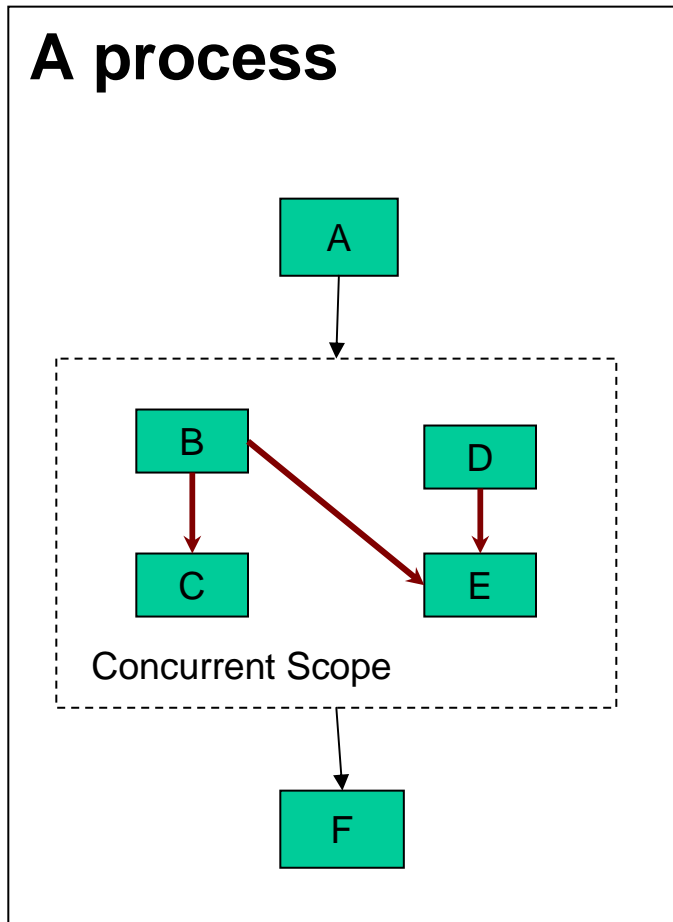



Properties of Business Processes

- **A business process should**
 - **Terminate**
 - **A transition is in a finite sequence**
 - **1-safe**
 - **Reversible**
- **Or, if you connect the Receive-Reply with a pseudo transition**
 - **Deadlock-free**
 - **Live**
 - **1-safe**
 - **Reversible**



Add parameters to Petri nets for BEPL activities

- **Associate variables with places**
- **Associate conditions with transitions**

The Petri Net for the Internal Behavior of an Activity [Aalst05]

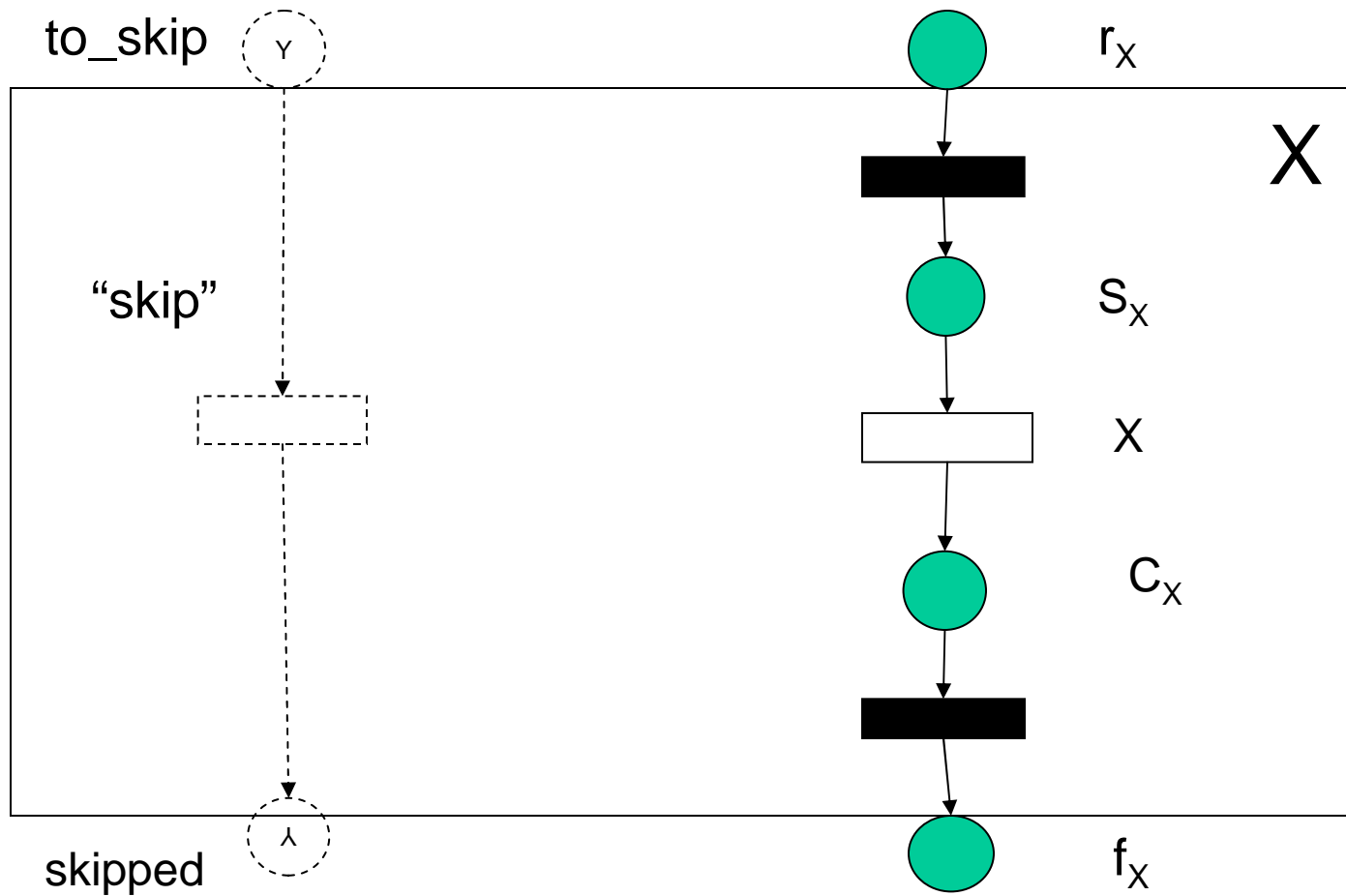



Basic Analysis Techniques in Petri Nets

- **Linear-algebraic techniques**
 - The marking equation
 - Place invariants
 - Transition invariants
- **Structural techniques**
 - Siphons
 - Traps
 - The siphon/trap property
- **Restricted net classes**
 - State machines
 - Marked graphs
 - Free-choice nets
- **Causal Semantics**
 - Occurrence nets
 - Process nets